

FX40

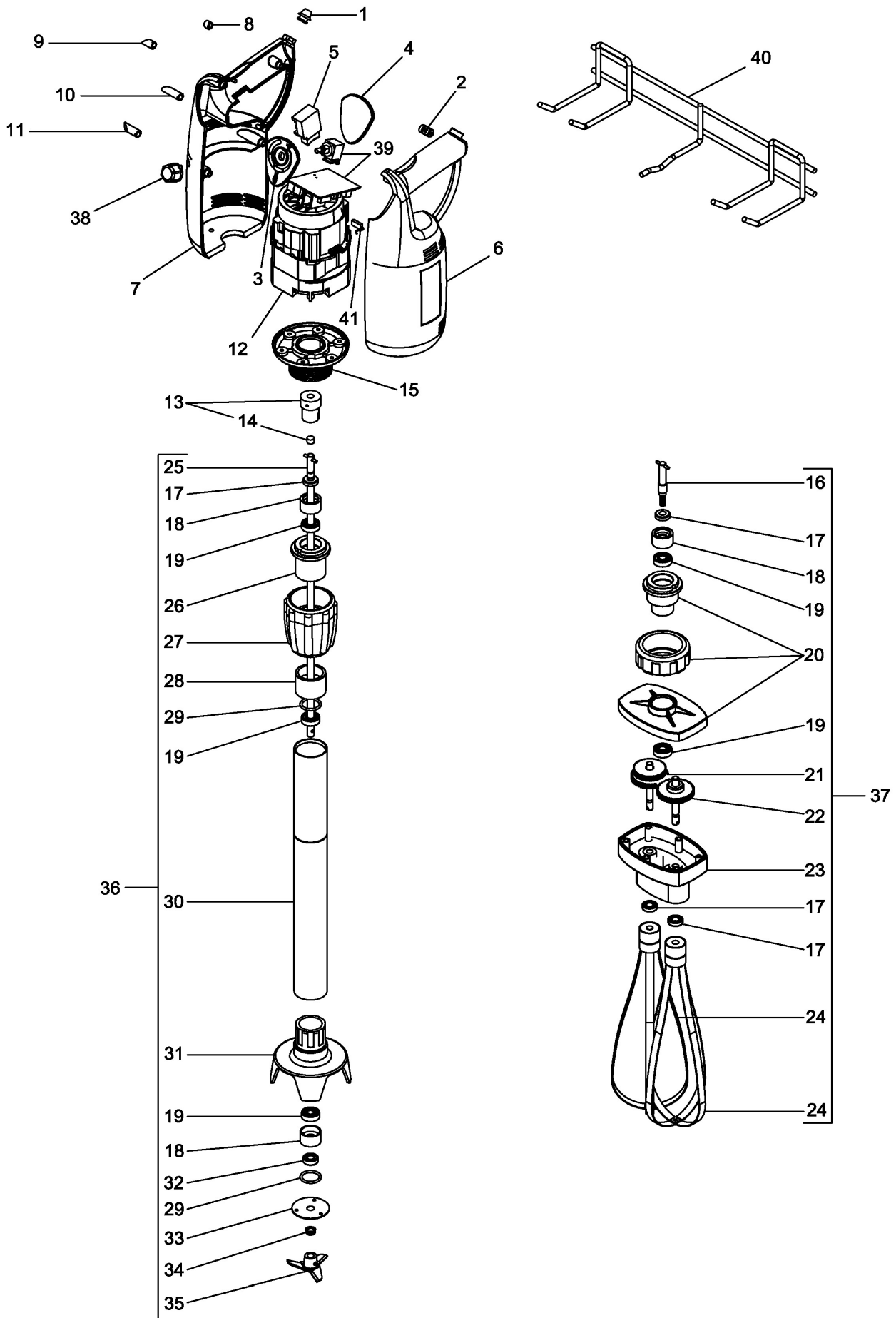

FX40

Pos. Ref.	Codice Code	Caratteristiche Features	Descrizione Description
1	SL0762		Pressacavo Cable clamp
2	SL3382	Green	Piastra Plate
3	SL3375	(FX40)	Inserto Insert
4	SL3442	Green (FX42S)	Inserto Insert
5	SL0757	●	Pulsante Push button
6	SL3374	Green	Copertura Covering
7	SL3373	Green	Copertura Covering
8	SL3381	Green	Tappo Tap
9	SL3380	Green	Tappo Tap
10	SL3378	Green	Tappo Tap
11	SL3379	Green	Tappo Tap
12	SL2899	● 230V/1Ph/50-60Hz	Motore Motor
13	SA1063	●	Giunto Joint
14	SL3611		Inserto Insert
15	SL3612	Green	Flangia Flange
16	SL0739	● (FX40)	Ingranaggio Gear
17	SL0746	∅8x∅18x6	Paraolio Oil seal
18	SL0740		Boccola Bush
19	SL0271	● 608H ZZ inox	Cuscinetto Bearing
20	SA1002	Assembly (FX40)	Supporto Support
21	SA8900	● (FX40)	Ingranaggio Gear
22	SA8800	● (FX40)	Ingranaggio Gear
23	SL0733	(FX40)	Scatola Box
24	SL0743	● (FX40)	Frusta Whisk
25	SL0976	L=300mm	Albero Shaft
25	SL0776	L=400mm (standard)	Albero Shaft
25	SL0978	L=500mm	Albero Shaft
25	SL0979	L=600mm	Albero Shaft
26	SL0741		Supporto Support
27	SL3391		Ghiera Locking ring
28	SL0879		Boccola Bush
29	SL0773	OR 129	O-ring O-ring
30	SL0972	L=300mm	Tubo Tube
30	SL0747	L=400mm (standard)	Tubo Tube
30	SL0974	L=500mm	Tubo Tube
30	SL0975	L=600mm	Tubo Tube
31	SL3415		Protezione Protection
32	SL1454	∅8x∅18x7	Paraolio Oil seal
33	SL0777		Disco Disk
34	SL0772	V-8-S	V-ring V-ring
35	SL0744	●	Coltello Cutter
36	ME4030	L=300mm assembly	Utensile mescolatore Mixer tool
36	ME4040	L=400mm assembly (standard)	Utensile mescolatore Mixer tool
36	ME4050	L=500mm assembly	Utensile mescolatore Mixer tool
36	ME4060	L=600mm assembly	Utensile mescolatore Mixer tool
37	FRUSTAFM3	Assembly (FX40)	Utensile frusta Whisk tool
38	SL3376	(FX40)	Pomello Knob
39	SL2997	● 230V/1Ph/50-60Hz (FX40)	Scheda elettronica Electronic card
40	SL0771		Portautensili Accessory stand
41	SL3843	●	Spazzola Brush

(*): fuori produzione / out of production

● : ricambio consigliato / spare part suggested